

Chapter 8.5: Angles of Elevation and Depression Worksheet

Solve each problem. Round measures of segments to the nearest tenth and measures of angles to the nearest degree.

_____ 1. A 20-foot ladder leans against a wall so that the base of the ladder is 8 feet from the base of the building. What is the ladder's angle of elevation?

_____ 2. A 50-meter vertical tower is braced with a cable secured at the top of the tower and tied 30 meters from the base. What is the angle of depression from the top of the tower to the point on the ground where the cable is tied?

_____ 3. At a point on the ground 50 feet from the foot of a tree, the angle of elevation to the top of the tree is 53° . Find the height of the tree.

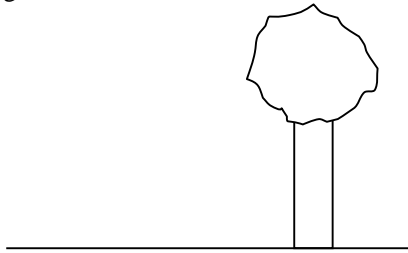

_____ 4. From the top of a lighthouse 210 feet high, the angle of depression of a boat is 27° . Find the distance from the boat to the foot of the lighthouse. The lighthouse was built at sea level.

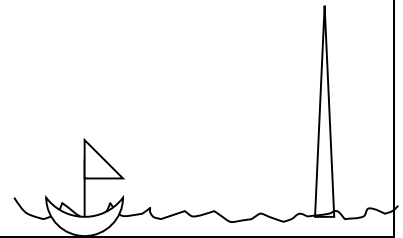

_____ 5. Mrs. Skaff is flying a kite. The kite string has an angle of elevation of 57° . If Mrs. Skaff is standing 100 feet from the point on the ground directly below the kite, find the length of the kite string.

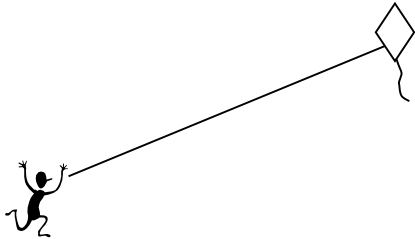

_____ 6. An airplane rises vertically 1000 feet over a horizontal distance of 5280 feet. What is the angle of elevation of the airplane's path?

_____ 7. A person at one end of a 230-foot bridge spots the river's edge directly below the opposite end of the bridge and finds the angle of depression to be 57° . How far below the bridge is the river?

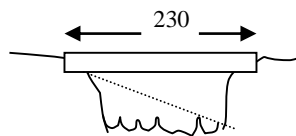

_____ 8. The angle of elevation from a car to a tower is 32° . The tower is 150 ft. tall. How far is the car from the tower?

_____ 9. A radio tower 200 ft. high casts a shadow 75 ft. long. What is the angle of elevation of the sun?

_____ 10. An escalator from the ground floor to the second floor of a department store is 110 ft long and rises 32 ft. vertically. What is the escalator's angle of elevation?

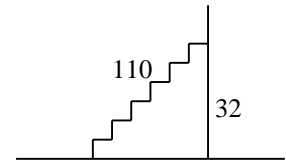

_____ 11. A rescue team 1000 ft. away from the base of a vertical cliff measures the angle of elevation to the top of the cliff to be 70° . A climber is stranded on a ledge. The angle of elevation from the rescue team to the ledge is 55° . How far is the stranded climber from the top of the cliff? (Hint: Find y and w using trig ratios. Then subtract w from y to find x)

_____ 12. A ladder on a fire truck has its base 8 ft. above the ground. The maximum length of the ladder is 100 ft. If the ladder's greatest angle of elevation possible is 70° , what is the highest above the ground that it can reach?

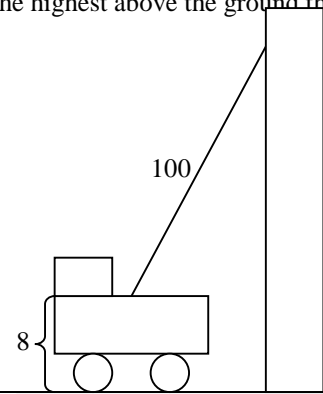
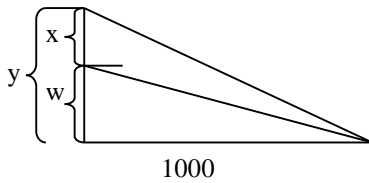

_____ 13. A person in an apartment building sights the top and bottom of an office building 500 ft. away. The angle of elevation for the top of the office building is 23° and the angle of depression for the base of the building is 50° . How tall is the office building?

_____ 14. Electronic instruments on a treasure-hunting ship detect a large object on the sea floor. The angle of depression is 29° , and the instruments indicate that the direct-line distance between the ship and the object is about 1400 ft. About how far below the surface of the water is the object, and how far must the ship travel to be directly over it?

